

## Option for motorized test stand

---

EN-00

### Speed / length meter



MV-500NII-E / MX-500N-E



MX-2000N-E

\* Force gauge is sold separately

#### [Applications]

- For tendency of measuring by different speed
- Valuation test of switches
- For peel adhesion strength test
- Valuation test of springs

#### [Feature]

- This is option for motorized stand. Please use suffix “-E” after model name of stand.
- To increase the repeatability of measuring keeping fixed speed
- Hold and zero clear function

## [Specification]

Model	EN-00
Display	9999.99mm (Max)
Resolution	0.01mm
Accuracy	0.1mm (Max)
Resolution for speed	1mm / minute
Function	Zero reset (for length) Display hold (for both speed/length)
Available test stands	MV-500II-E MX-500N-E MX-2000N-E

See the each specifications for the detail of test stand.

This speed/length meter is option of motorized stand. Please order this with test stand

It is required to install to a stand before ship.

[Dimension]

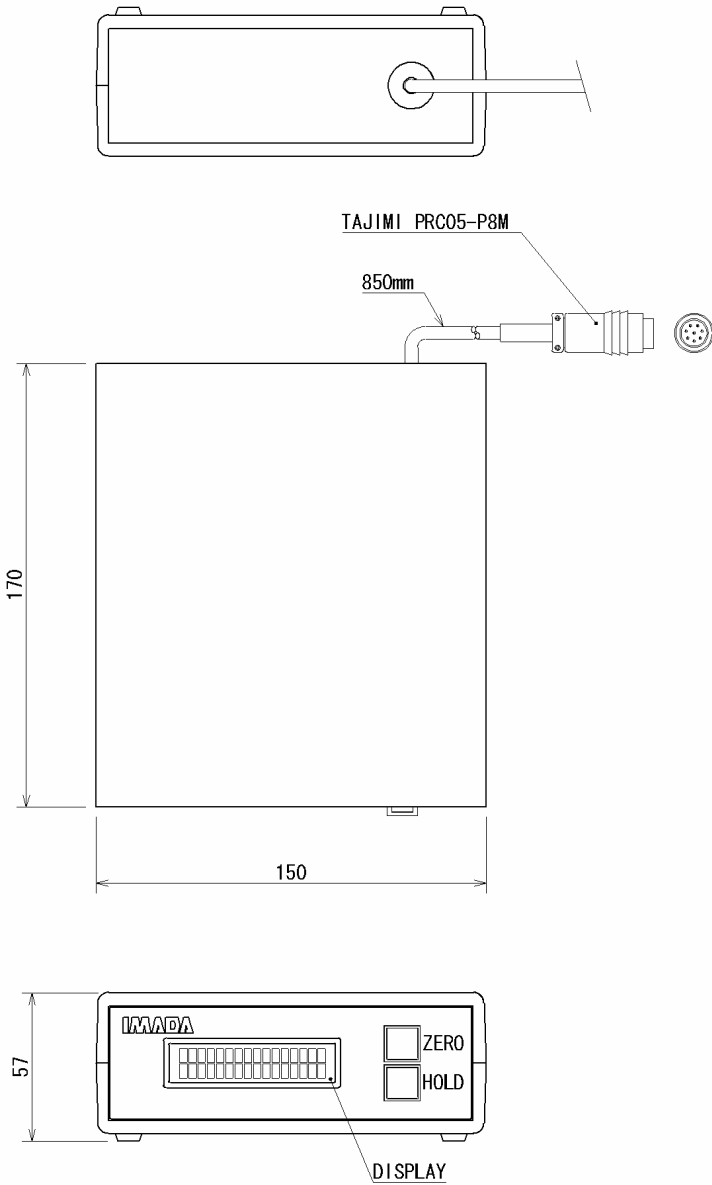

[Note]

- Force gauges are sold separately.
- Various optional attachments are available.
- It may change without a preliminary announcement for improvement etc.