

Load cells for FA Plus (Desktop force amplifier)

LM / LC series

Compression load cells



LM series



LC series

[Application]

- The load cells are used to measure force for FA Plus series.

[Feature]

- They are small and light compression load cells, and easy to set up and handle.
- The load cells show excellent stability and reliability for measuring force due to their enclosed structure so that they can be used regardless their surrounding environment (LC series). The stainless steel (SUS630) is adapted for LC series so that they are superior in anticorrosion.

[LM / LC series specifications]

Compression load cell

Model	LM-10N to 20kN	LC-500N to 20kN
Feature	Minute force model	General force model [Stainless steel]
Capacity	Refer to each models	Refer to each models
Rated output	LM-10N~1000N: 0.75 to 2mV / V LM-2000N~20kN: Over 1mV / V	2mV / V
Nonlinearity	Within +/-1%RO	Within +/-0.15%RO
Hysteresis	Within +/-1%RO	Within +/-0.1%RO
Recommended voltage (Permissible applied voltage)	LM-10N~1000N:1to 5V AC or DC LM-2000N~20kN:1to 2V AC or DC (7V AC or DC)	1 to 12V AC or DC (20V AC or DC)
Input/output resistance	LM-10N~1000N: 350ohm +/-2.5% LM-2000N~20kN: 350ohm +/-2 %	Approx. 350 ohm +/-0.5%
Permissible over load	LM-10N~1000N:150% LM-2000N~20kN:120%	200%
Operating temperature	0 to 50 degree Celsius	-10 to 70 degree Celsius
Weight	~LM-1000N:Approx.20g ~LM-2000N:Approx. 25g	Approx. 220g
Cable	2m(with connector)	3m(with connector)
Dimension	Refer to the drawing	Refer to the drawing

[Models]

Model	Capacity (Reference values)	Permissible over load	Remark	
LM-10N	10N (1kgf)	150%	diameter12×H4	
LM-20N	20N (2kgf)			
LM-50N	50N (5kgf)			
LM-100N	100N (10kgf)		120%	diameter20×H8.5
LM-200N	200N (20kgf)			
LM-500N	500N (50kgf)			
LM-1000N	1000N (100kgf)			
LM-2000N	2000N (200kgf)	200%	diameter20×H9.5	
LM-5000N	5000N (500kgf)		diameter21×H10	
LM-10kN	10kN (1000kgf)			
LM-20kN	20kN (2000kgf)			
LC-500N	500N (50kgf)	200%	Material:SUS630	
LC-1000N	1000N (100kgf)			
LC-2000N	2000N (200kgf)			
LC-5000N	5000N (500kgf)			
LC-10kN	10kN (1000kgf)			
LC-20kN	20kN (2000kgf)			

- * Please order Imada's desktop force amplifier FA Plus (refer to the catalog) together with the load cells so that their combined calibration can be done when they are shipped.
- * Please refer to the sensor separate type digital force gauge: Z2S/ZPS series (the catalogue available separately) as LM/LC series are installed as standard.

[Dimensional drawing]

LM series

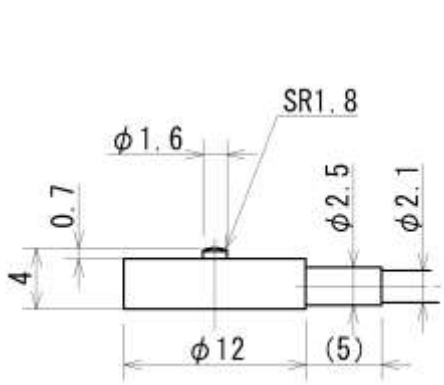

[LM-10N~50N]

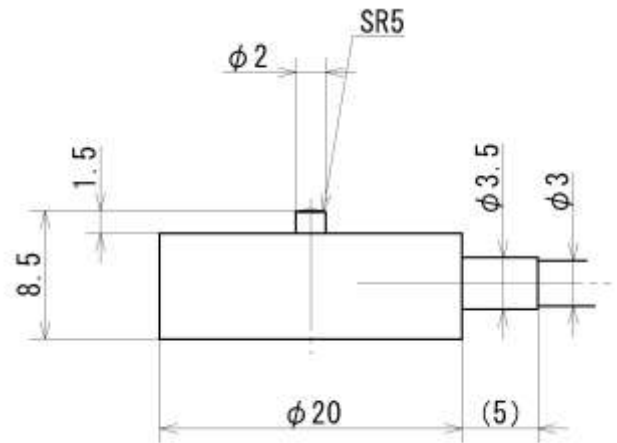

[LM-100N~1000N]

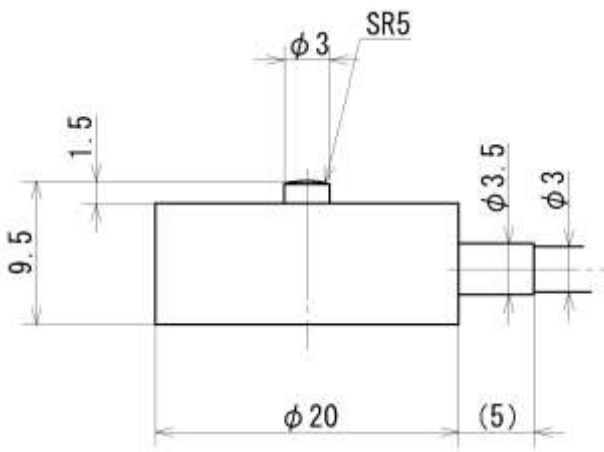

[LM-2000N]

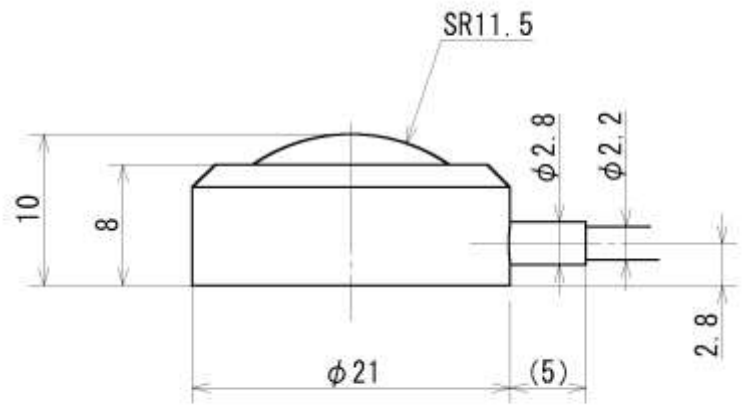

[LM-5000N~20kN]

LC series

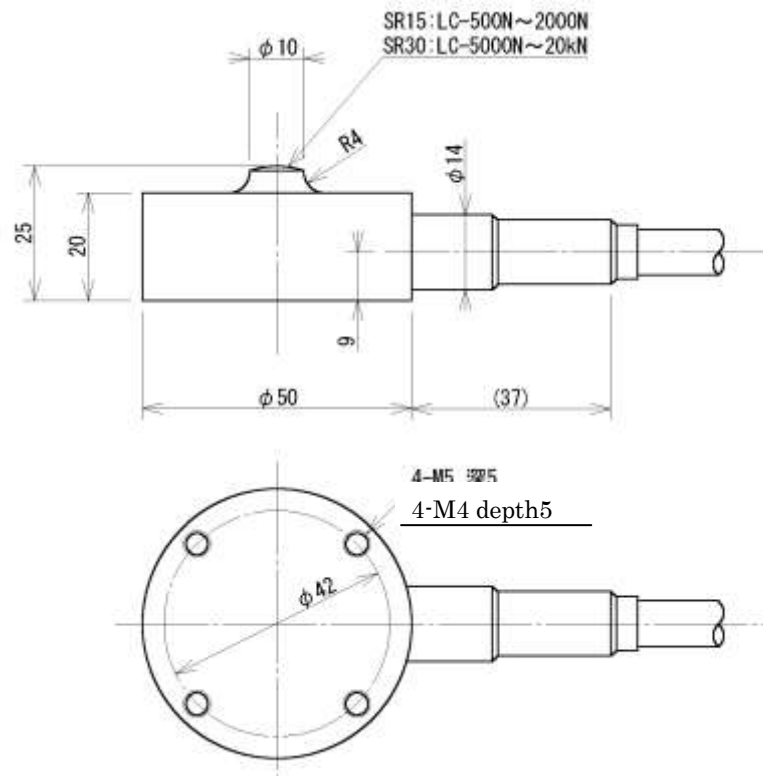

[Precaution]

- Please pay close attention for the installation of the load cells.
 - Never apply strong force or impact especially on the sensing direction.
 - Do not apply bending or torsion stress when setting up the sensing shaft to a measuring object.
- Do not use in the condition of rapid temperature changes, high temperature, high humidity, near water and dusty place.
- All information is subject to change without prior notice.