

Load cells for FA Plus (Desktop force amplifier)

LU / DPU series

Tensile and Compression load cells

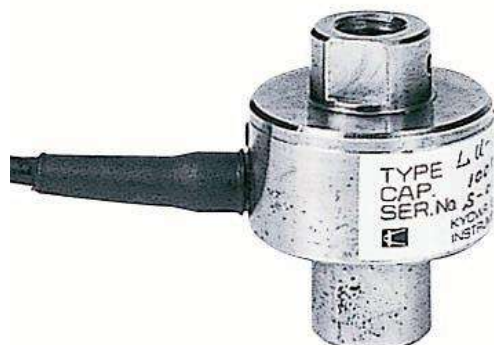

LU series



DPU-2N to 500N series



DPU-1000N to 20kN series

[Application]

- The load cells are used to measure force for FA Plus.

[Feature]

- The load cells are capable of measuring both tensile and compression force.

[LU / DPU series specifications]

Model	LU-50N to 2000N	DPU-2N to 500N	DPU-1000N to 20kN
Feature	Cylinder type	For normal force	For heavy force
Capacity	Refer to specification	Refer to specification	Refer to specification
Rated output	Over +/- 0.5mV / V (LU-50N : 0.4mV/V)	1mV / V +/- 10%	2mV / V +/- 1%
Nonlinearity	Within +/- 0.5%RO	0.15%RO	0.1%RO
Hysteresis	Within +/- 0.5%RO	0.15%RO	0.1%RO
Recommended voltage (Permissible applied voltage)	1 to 2V AC or DC (7V AC or DC)	2 to 5V DC (12V DC)	10V DC (18V DC)
Input/output resistance	350 ohm +/- 2%	Approx. 350 ohm	350 ohm +/- 1%
Permissible over load	150%	Refer to specification	Refer to specification
Operating temperature	0 to 70 degree Celsius	0 to 50 degree Celsius	-10 to 70 degree Celsius
Sensing shaft diameter	None	M6	M10 P1.5
Weight	Approx. 80g	Approx. 325g	Approx.800g DPU-10kN:Approx.1.7kg DPU-20kN:Approx.2.3kg
Cable	3m(With connector)	2m(With connector)	3m(With connector)
Dimension	Diameter 28×H35	Refer to the drawing	Refer to the drawing

[LU / DPU series available models]

Model	Capacity (Reference values)	Permissible over load	Sensing shaft diameter	
LU-50N	+/-50N (+/-5kgf)	150%	None	
LU-100N	+/-100N (+/-10kgf)			
LU-200N	+/-200N (+/-20kgf)			
LU-500N	+/-500N (+/-50kgf)			
LU-1000N	+/-1000N (+/-100kgf)			
LU-2000N	+/-2000N (+/-200kgf)			
DPU-2N	+/-2N (+/-250gf)	150%	M6 P1	
DPU-5N	+/-5N (+/-500gf)			
DPU-10N	+/-10N (+/- 1kgf)	200%		
DPU-20N	+/-20N (+/- 2kgf)			
DPU-50N	+/-50N (+/- 5kgf)			
DPU-100N	+/-100N (+/-10kgf)			
DPU-200N	+/-200N (+/-20kgf)			
DPU-500N	+/-500N (+/-50kgf)			
DPU-1000N	+/-1000N (+/-100kgf)	240%		M10 P1.5
DPU-2000N	+/-2000N (+/-200kgf)	120%		
DPU-5000N	+/-5000N (+/-500kgf)			
DPU-10kN	+/-10kN (+/-1000kgf)	120%	None	
DPU-20kN	+/-20kN (+/-2000kgf)			

* Please order Imada's desktop force amplifier FA Plus (refer to the catalog) together with the load cells so that their combined calibration can be done when they are shipped.

* Please refer to the separate sensor type digital force gauge: ZPS/Z2S-DPU series (the catalog available separately) as the above DPU load cells are installed as standard.

[Dimensional drawing]

LU series

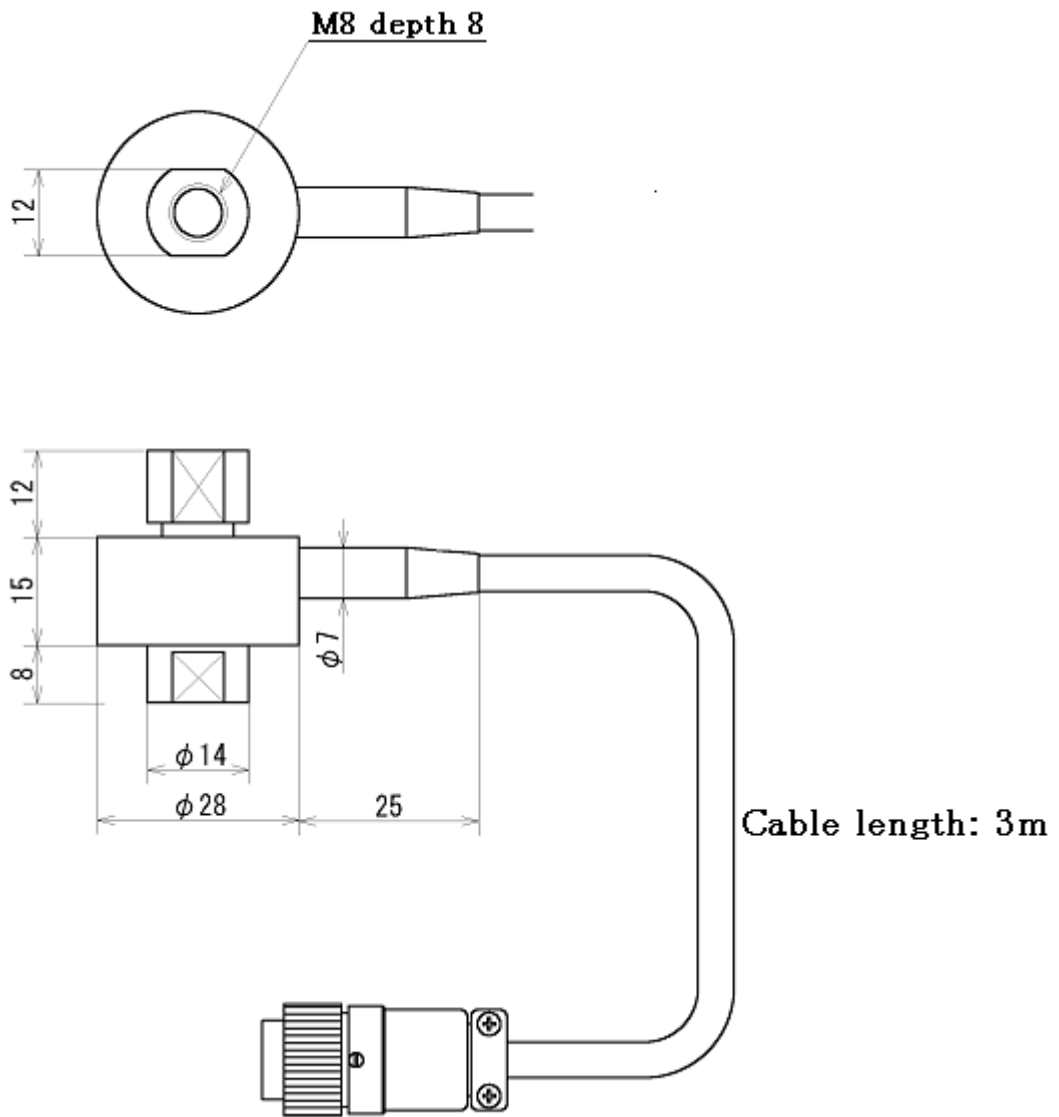

DPU-2.5N to 500N series

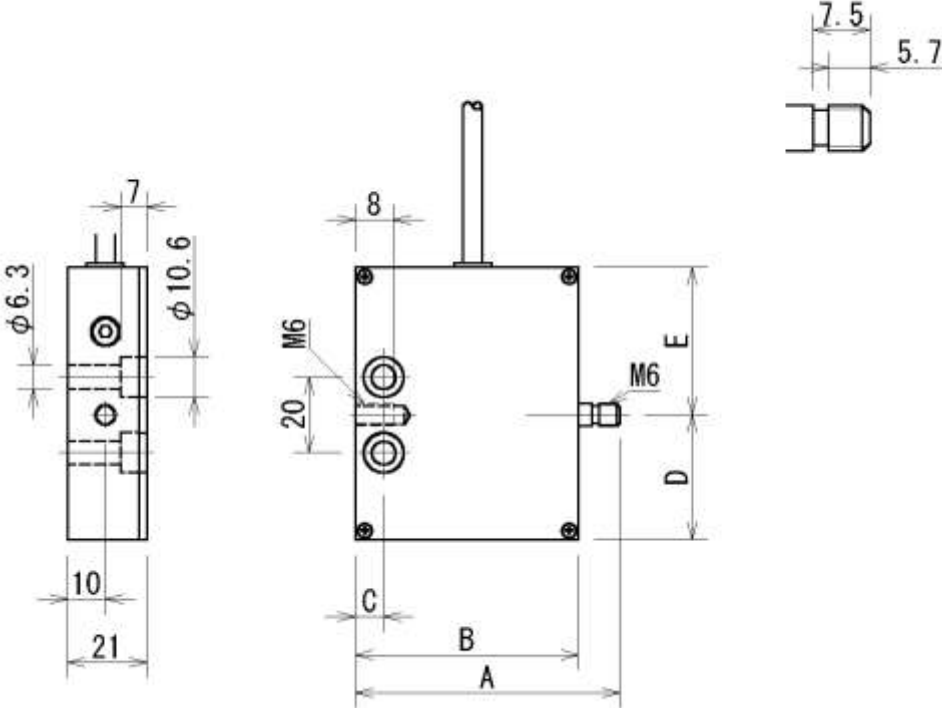

Model	A	B	C	D	E
DPU-2.5N	71	57	12	26	32
DPU-5N	71	57	12	26	32
DPU-10N	71	57	12	26	32
DPU-20N	73	59	7.5	33	39
DPU-50N	73	59	7.5	33	39
DPU-100N	73	59	7.5	33	39
DPU-200N	73	59	7.5	33	39
DPU-500N	73	59	7.5	33	39

DPU-1000N to 20kN series

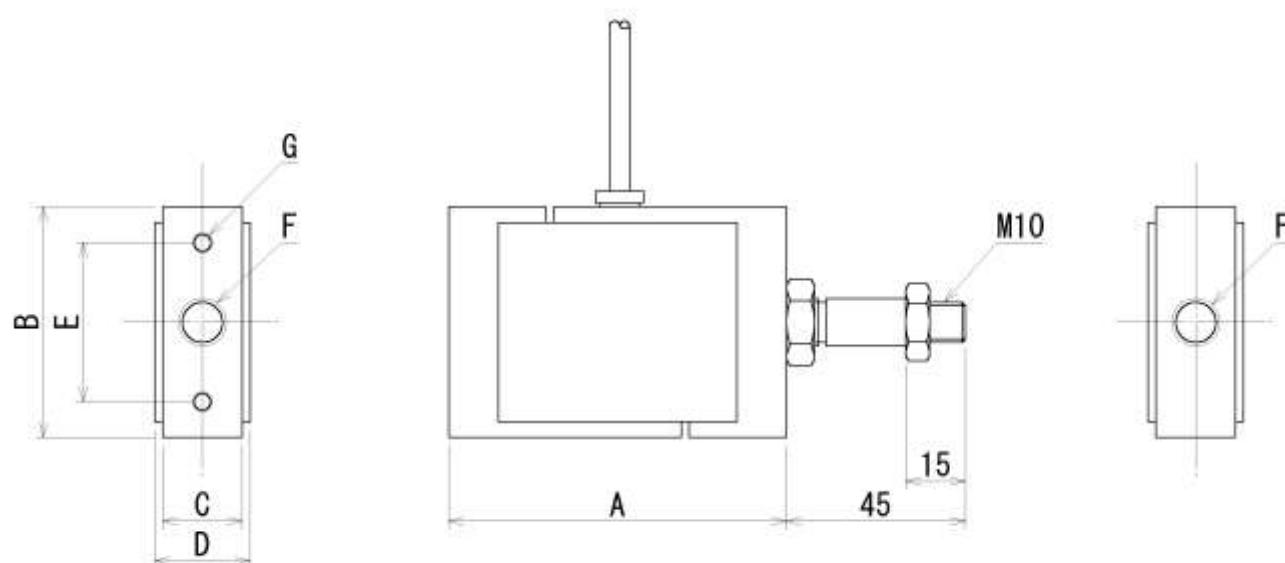

Model	A	B	C	D	E	F	G	Remark
DPU-1000N	85	58	20	24	40	M12 P1.75 Depth 15	M5 Depth 8	With sensing shaft
DPU-2000N	85	58	20	24	40	M12 P1.75 Depth 15	M5 Depth 8	With sensing shaft
DPU-5000N	85	58	20	24	40	M12 P1.75 Depth 15	M5 Depth 8	With sensing shaft
DPU-10kN	105	78	32	36	60	M18 P1.5 Depth 22	M6 Depth 10	Without sensing shaft
DPU-20kN	110	88	35	40	60	M18 P1.5 Depth 22	M6 Depth 10	Without sensing shaft

[Precaution]

- Please pay close attention for the installation of the load cells.
 - Never apply strong force or impact especially on the sensing direction.
 - Do not apply bending or torsion stress when setting up the sensing shaft to a measuring object.
- Do not use in the condition of rapid temperature changes, high temperature, high humidity, near water and dusty place.
- All information is subject to change without prior notice.