

45 degree film peeling test fixture

P45-50N

It is fit for peeling test of packaging film especially in food or medical industries.
It can start peeling with angle 45 degree, which is nearly practical condition.
It can conduct a test easily in accordance with JIS [Japanese Industry Standard].











[Characteristics]

Able to measure various size of containers	Meet JIS [Japanese Industry Standard]
Sample size should be height:10-100mm, diameter:20-140mm, however, we provide made-to-order only for your sample, so please have a talk.	Possible to measure in accordance with JIS:S0022 [Policy for the elderly and handicapped -Packaging/container- How to test open-easiness.]

[Combination Example]

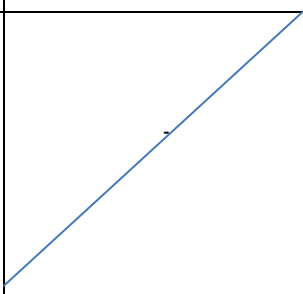
Composition Example											
<div style="border: 1px solid black; padding: 5px; margin-bottom: 10px;">Force control cable [CB-704]</div> <div style="border: 1px solid black; padding: 5px; margin-bottom: 10px;">Digital force gauge [ZP-50N]</div> <div style="border: 1px solid black; padding: 5px; margin-bottom: 10px;">45 degree film peeling test fixture [P45-50N]</div> <div style="border: 1px solid black; padding: 5px;">Motorized test stand (long stroke / special speed range version) [MX2-500N-L-V600]</div>		<p>[Option Added Models]</p> <table border="1" style="width: 100%; border-collapse: collapse; text-align: center;"> <thead> <tr style="background-color: #D9E1F2;"> <th style="width: 20%;"></th> <th style="width: 40%;">According to JIS</th> <th style="width: 40%;">Not according to JIS</th> </tr> </thead> <tbody> <tr> <td style="text-align: left;">Sample's height: higher than 70mm</td> <td>MX2-500N-L-V600</td> <td>MX2-500N-L</td> </tr> <tr> <td style="text-align: left;">Sample's height: lower than 70mm</td> <td>MX2-500N-V600</td> <td>MX2-500N (Standard)</td> </tr> </tbody> </table> <p>-L: long stroke (200mm extended) option -V600: special speed range (20-600mm/min) option (When the option is added, the maximum capacity will be down to 250N.)</p> <p>※ This application is just one of the examples. There could be non-measurable samples.</p>		According to JIS	Not according to JIS	Sample's height: higher than 70mm	MX2-500N-L-V600	MX2-500N-L	Sample's height: lower than 70mm	MX2-500N-V600	MX2-500N (Standard)
	According to JIS	Not according to JIS									
Sample's height: higher than 70mm	MX2-500N-L-V600	MX2-500N-L									
Sample's height: lower than 70mm	MX2-500N-V600	MX2-500N (Standard)									

	45 degree film peeling test fixture	Digital force	Force control cable	Motorized test stand
How to Test 1 [meet JIS] In accordance with JIS:S0022	[P45-50N] 	[ZP series] *1 	[CB-704]*2 	[MX2-500N] *3 
How to Test 2 [More easily] At lower cost		[DS2 series] 		[MX2-500N]*3 

*1 We recommend digital force gauge since it is more fit for impact test in 45 degree film peeling test

*2 We recommend CB-704 since function of overload prevention works with it connected to a test stand.

*3 We recommend MX2 series since it can set up moving speed. Please refer to [Option Added Models] in the table about models with option.

[Applications]

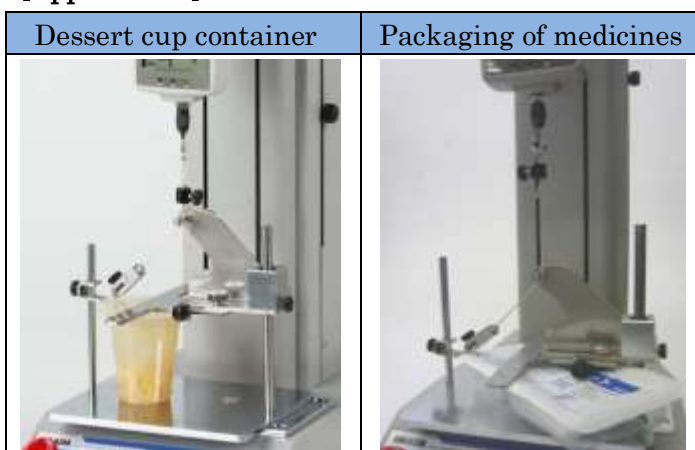

[P45-50N Specifications]

P45-50N	
Capacity	50N
Maximum sample size	Height 10-100mm Diameter 20-140mm
Force gauge used together	ZP、Z2、DS2 series
Test stand available	MX-500N、1000N MX2-500N、1000N HV-1000N
Sample grip	
Weight	Approx.10g
Maximum opening width	2mm
Table	
Weight	Approx.1500g

*Area to be peeled is different according to container's size.

[Dimensions]

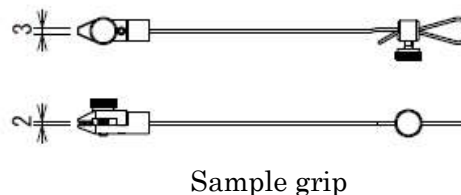
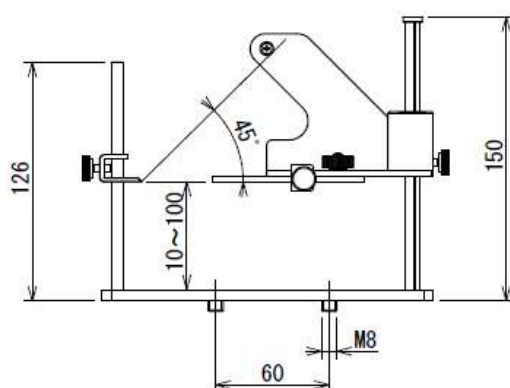
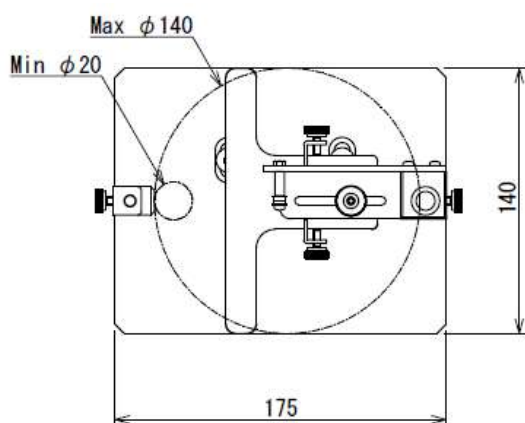

[Cautions]

- *The contents may be changed without notice in advance.
- *This product is designed for measurement purpose only.
- *Do not copy the contents without permission.
- *This is necessary to be used together with a force gauge and a test stand.