

PSS/PS/PSM/FB/FS Series

Mechanical Force Gauge

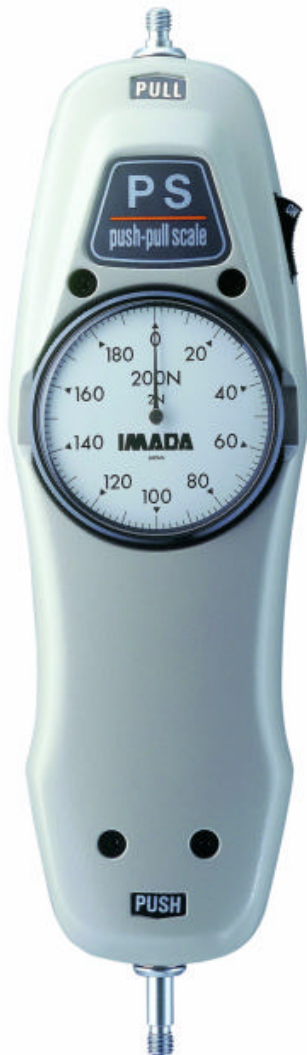

PS



PSM



FB



FB-KITS

[Application]

Measuring of the contact pressure for touch panel or keyboard

Measuring of the bonding strength of adhesive tapes and the peel strength of adhesive sheets

*Digital force gauges are more suitable for measuring rapid change of the force such as impact test

[Feature]

All models are equipped with Peak Hold function which captures peak force.

Zero adjustment function for tare weight allows the adjustments of attachment's weight.

[PSS/PS/PSM/FS/FB Series Specification]

Model	PSS	PS	PSM	FS	FB
Stroke	10 mm				
Measuring units	Refer to the following tables				
Display features	Track and peak mode (Selectable)				
Graduation	100 lines*		200 lines **	100lines *	
Accuracy	+/-0.1% of F.S			+/-0.3% of F.S	
Operating temperature range	0~+40 degree Celsius				
Weight	530 g	600 g		530 g	600 g
Accessories	8 attachments Carrying case			6 attachments Carrying case	

* 120 lines for 3K, 30K, 300N, 30lb, 300K, 300N, 300lb.

** 150 lines for 3K, 30K.

[PSS/PS/PSM/FS/FB available models]

1. PPS/PS Series: Highly Accurate, Durable Standard Model

PS Series [N unit graduation: 100 lines *120 lines]

Model	Capacity	Resolution
PS-5N	5 N	0.05 N
PS-10N	10 N	0.1 N
PS-20N	20 N	0.2 N
PS-30N *	30 N	0.25 N
PS-50N	50 N	0.5 N
PS-100N	100 N	1 N
PS-200N	200 N	2 N
PS-300N *	300 N	2.5 N
PS-500N	500 N	5 N

PSS Series [Kg unit graduation: 100 lines *120 lines] Note 1)

Model	Capacity	Resolution
PSS-0.5K	500 gf	5 gf
PSS-1K	1 kgf	10 gf
PSS-2K	2 kgf	20 gf
PSS-3K *	3 kgf	25 gf

PS Series [Kg unit graduation: 100 lines *120 lines] Note 1)

Model	Capacity	Resolution
PS-5K	5 kgf	50 gf
PS-10K	10 kgf	10 gf
PS-20K	20 kgf	20 gf
PS-30K *	30 kgf	25 gf
PS-50K	50 kgf	500 gf

PS Series [lb unit graduation: 100 lines *120 lines] Note 1)

Model	Capacity	Resolution
PS-5lb	5 lb	0.05 lb
PS-10lb	10 lb	0.1 lb
PS-20lb	20 lb	0.2 lb
PS-30lb *	30 lb	0.25 lb
PS-50lb	50 lb	0.5 lb
PS-100lb	100 lb	1 lb

Note 1)

Prohibited to sell Japanese market due to Japanese Measurement standard law.

2. PSM Series: High-Resolution Scale Precision Type

PSM Series [N unit graduation: 200 lines **150 lines]

Model	Capacity	Resolution
PS-20N	20 N	0.1 N
PS-30N **	30 N	0.2 N
PS-50N	50 N	0.25 N
PS-100N	100 N	0.5 N
PS-200N	200 N	1 N
PS-300N **	300 N	2 N
PS-500N	500 N	2.5 N

PSM Series [kg unit graduation: 200lines **150 lines] Note 1)

Model	Capacity	Resolution
PS-2K	2 kgf	10 gf
PS-3K	3 kgf	20 gf
PS-5K	5 kgf	25 gf
PS-10K	10 kgf	50 gf
PS-20K	20 kgf	100 gf
PS-30K **	30 kgf	200 gf
PS-50K	50 kgf	250 gf

Note 1)

Prohibited to sell Japanese market due to Japanese Measurement standard law.

3. FB/FS Series: Steady Accuracy, Affordable Price Popular Type

FB Series [N unit graduation: 100 lines*120 lines]

Model	Capacity	Resolution
FB-5N	5 N	0.05 N
FB-10N	10 N	0.1 N
FB-20N	20 N	0.2 N
FB-30N *	30 N	0.25 N
FB-50N	50 N	0.5 N
FB-100N	100 N	1 N
FB-200N	200 N	2 N
FB-300N *	300 N	2.5 N
FB-500N	500 N	5 N

FS Series [kg unit graduation: 100 lines *120 lines] Note 1)

Model	Capacity	Resolution
FS-0.5K	500 gf	5 gf
FS-1K	1 kgf	10 gf
FS-2K	2 kgf	20 gf
FS-3K *	3 kgf	25 gf

FS Series [kg unit graduation: 100 lines *120 lines] Note 1)

Model	Capacity	Resolution
FB-5K	5 kgf	50 gf
FB-10K	10 kgf	10 gf
FB-20K	20 kgf	20 gf
FB-30K *	30 kgf	25 gf
FB-50K	50 kgf	500 gf

FB Series [lb unit graduation: 100 lines *120 lines] Note 1)

Model	Capacity	Resolution
FB-5lb	5 lb	0.05 lb
FB-10lb	10 lb	0.1 lb
FB-20lb	20 lb	0.2 lb
FB-30lb *	30 lb	0.25 lb
FB-50lb	50 lb	0.5 lb
FB-100lb	100 lb	1 lb

Note 1)

Prohibited to sell Japanese market due to Japanese Measurement standard law.

[Dimension]

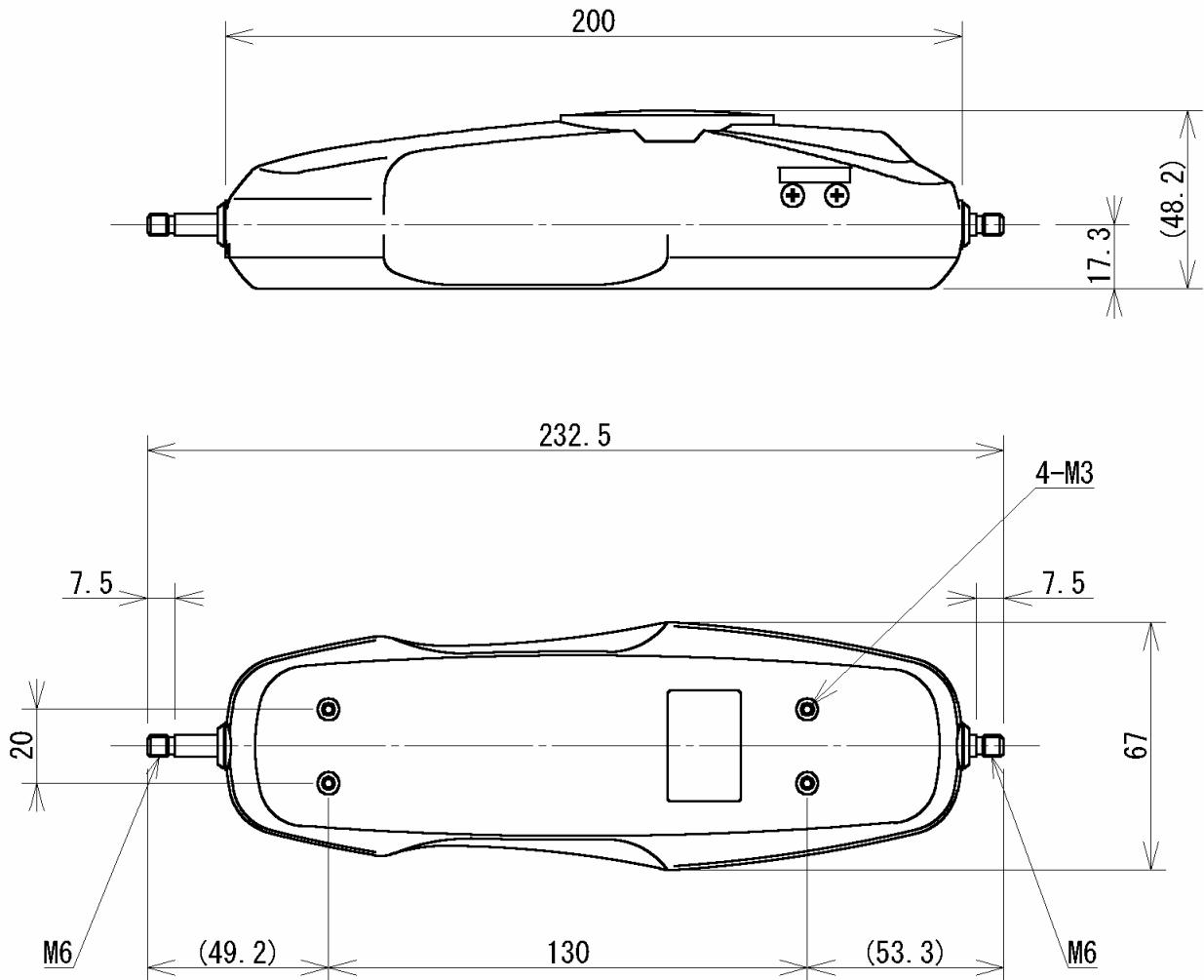

[Precautions]

- *Do not apply excess force, torque, or impact on the measuring shaft.
- *Do not use the gauge under the condition of the rapid temperature changes, high temperature, high humidity, near water and dusty place.
- *Keep the gauge in the exclusive carrying case when it is not used.
- *The use of the test stand made by Imada is recommended for the stable measuring result.
- *All information is subject to change without prior notice.