

## SV Series [SV-05(S) / SV-1]

## Handy-Type Manual Test Stand



SV-05 S



SV-1

(Force gauges are sold separately)

**[Applications]**

- Measuring of bonding strength of the lead wires for IC parts
- Measuring of contact press for touch panel or keyboard

**[Feature]**

- Two types available: Handle Wheel type (SV-05(S)) is for fine movement and stable pressure application. Lever type (SV-1) is for speedy pressure application.
- The test stand with distance meter (SV-05S) is to measure force and move distance with the length resolution 0.01 mm.
- It is easy to transport due the compact bench model.

## [SV-05(S) /SV-1 Specifications]

Model	SV-05	SV-05S	SV-1
Capacity	20N		500N
Fixed position	140mm		240 mm
	(maximum stroke without gauge)		
Drive Distance	Small knob 22.5 mm/rev		Lever 60 mm/operation
Mechanical stopper	None		Available
Stroke (Adjustment)	0~70mm None		Adjustable up to maximum 60 mm Available
Length gauge Resolution	None	Available 0.01 mm	None
Table dimension	Base integrated		100×150 mm
Thread hole pitch	(M8) 60 mm		(M8) 60 mm
Gauge mounting plate dimension	60×140 mm		60×189 mm
	(Refer to the following drawings for gauge mounting plate hole pitch)		
Dimension	05 : W200×D150×H258 mm 05S : W200×D150×H269 mm		W200×D(249)×H410 mm
Weight	2 kg	2.4 kg	9 kg
Optional long stroke	None	None	(-L600) Up to 600mm
Accessory	Force gauge mounting bolts		

[Dimension]

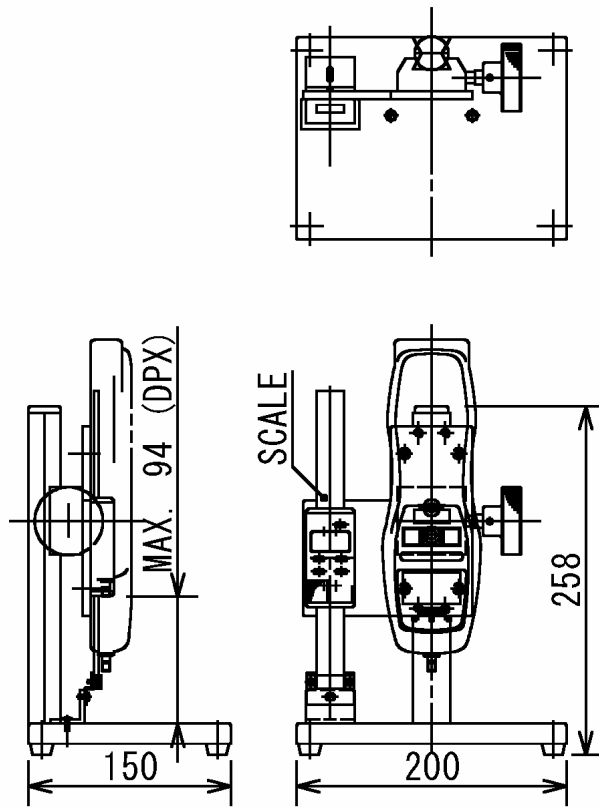

[SV-05S]

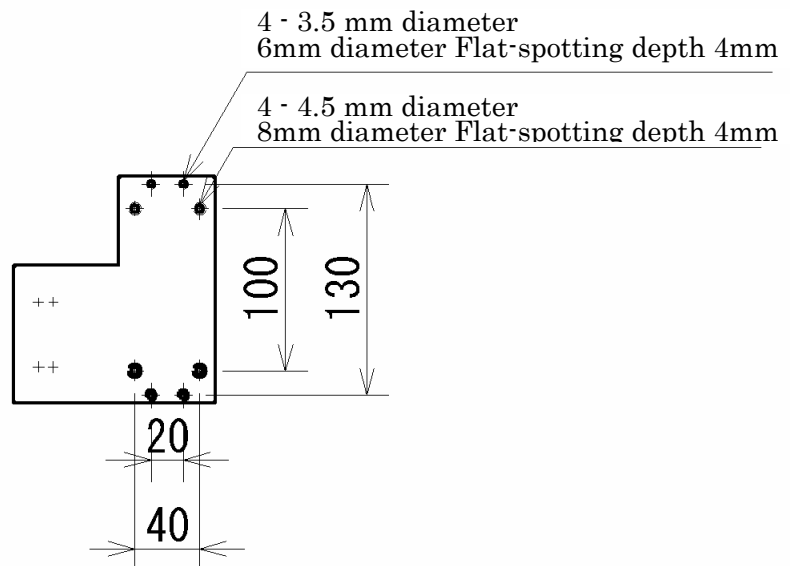

[Force gauge mounting plate] (SV-05S)

\* Same as SV-05

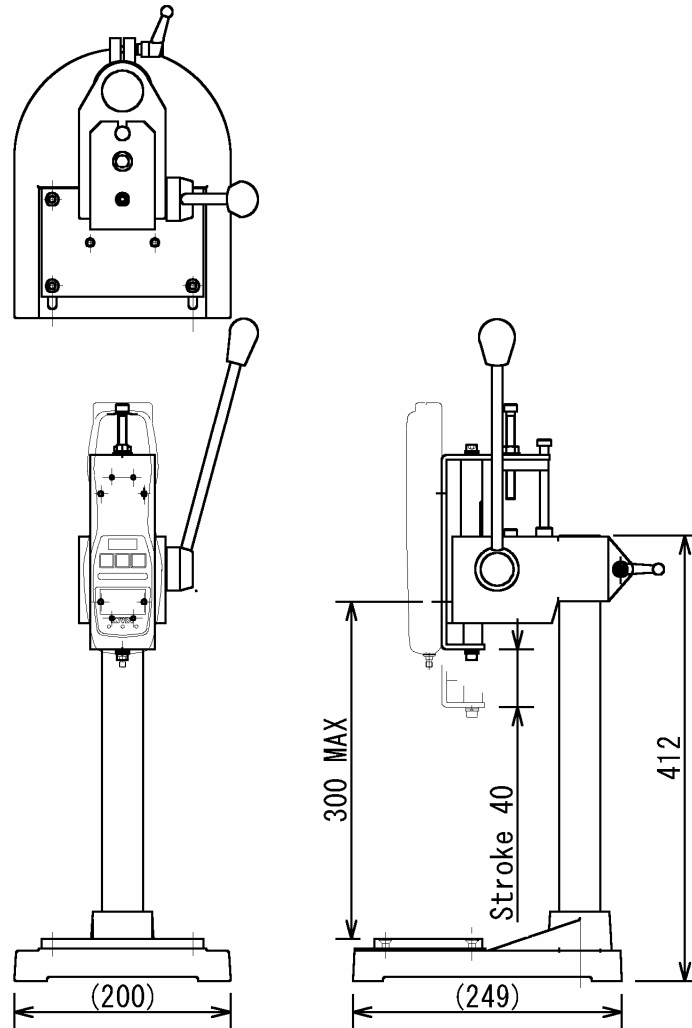

[SV-1]

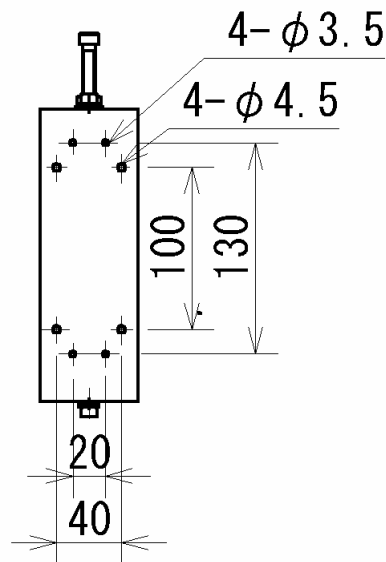

[Force gauge mounting plate]

\* For model SV-1

[Note]

\*Force gauge (sold separately) is required for actual measuring. Please order Imada products.

\*Various optional attachments are available for different types of measurement.

\*All information is subject to change without prior notice.