

Rubber Roller APR-97 Series for Peel Test

- Enables the user to stick samples with an even pressure for more accurate measurement of peeling force
- Complies with corresponding part of ISO and JIS. The weight and size can be customized for other standards such as ASTM. A motorized roller is also available as a customized option.



APR-97-2K





APR-97-1K



| Related Standard *complying with corresponding part only | |
|--|---|
| APR-97-2K | <ul style="list-style-type: none"> • JIS Z 0237:2022 [Testing methods of pressure-sensitive adhesive tapes and sheets] • ISO 29862:2018 [Self adhesive tapes--Determination of peel adhesion properties] • ISO 29863:2018 [Self adhesive tapes--Measurement of static shear adhesion] |
| APR-97-1K | <ul style="list-style-type: none"> • JIS Z 0237:2022 [Testing methods of pressure-sensitive adhesive tapes and sheets] • ISO 29862:2018 [Self adhesive tapes--Determination of peel adhesion properties] <p>*Compliable only for samples with width 8.5mm to 17mm.</p> |

| Specifications | | |
|-----------------|----------------------|-----------|
| Model | APR-97-2K | APR-97-1K |
| Mass | 2000g | 1000g |
| Roller Width | 45mm | |
| Roller Material | Rubber(Hardness:A80) | |
| Dimensions | Refer to dimensions | |

| Related Products | | |
|--|--|---|
| 90 degree Peel Test Fixture P90-200N | 180 degree Peel Test Fixture P180-200N | High speed peel strength tester IPTS-20N/50N |
| Testing fixture for products such as adhesive tapes. | Testing fixture for products such as adhesive tapes. | Specialized peeling tester features high productivity with a wide speed range up to 1500mm/min. |
|  |  |  |

[Customization]

Customization of roller mass, width, outer diameter, etc. are available.
 Please contact us for customized products that comply with standards.

| Available customization | |
|---|--|
| Mass (*1) | 100 to 5000g |
| Width | 30 to 300mm |
| Material | Antistatic urethane rubber (Hardness: A80) (*2) |
| Standards (*3) (complying with corresponding part only) | -ASTM D3330/D3330M [Standard Test Method for Peel Adhesion of Pressure-Sensitive Tape] -ASTM D6252/D6252M [Standard Test Method for Peel Adhesion of Pressure-Sensitive Label Stocks at a 90°Angle] |
| Motorized roller |  <p>The motorized roller allows bonding of a sample at a certain pressure and at a constant speed to enhance testing repeatability.</p> |

*1 Limited on the combination of roller mass and width. Please contact us for details.

*2 Antistatic specification for preventing static electricity and so on.

*3 Please contact us for other standards.

[Dimensions for APR-97 series]

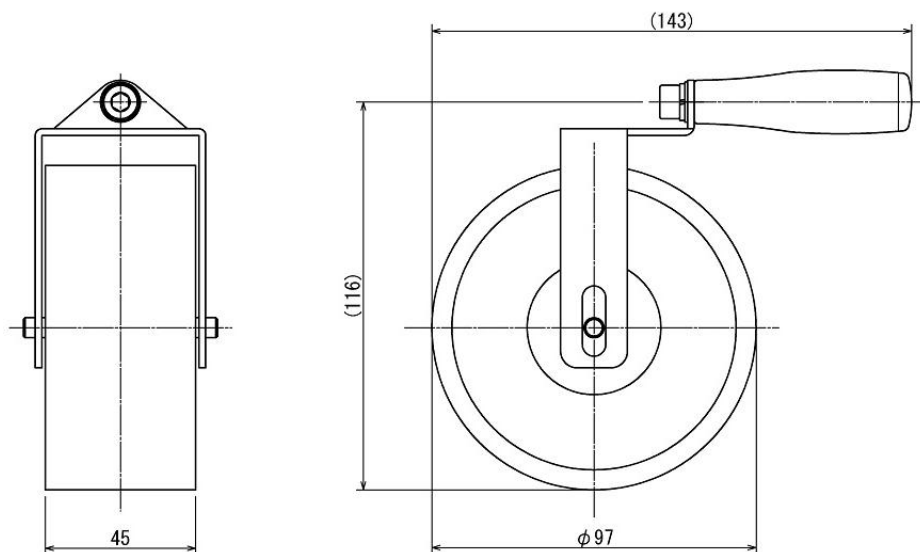

Unit:mm

[Cautions]

- Information in this document is subject to change without prior notice.
- This document is product descriptions and handling precautions, and do not guarantee various characteristics or safety.
- This product is designed for force measurement purpose only.
- Do not copy and use this content without authorization.

IMADA CO., LTD

99 Jinnoshinden-cho aza Kanowari Toyohashi
Japan 441-8077
Tel: +81-(0)532-33-3288
Fax: +81-(0)532-33-3866
E-mail: info@forcegauge.net
Website: <https://www.forcegauge.net/en/>



Visit our website for more information on a wide range of product specifications, measurement applications and videos.