

Pantograph Grip PGC series

Easy to grip samples with its cloth pin shaped design.
 Enables to grip easily deformable samples such as rubber and resin due to its self-tightening pantograph mechanism.



PGC-0505





PGC-0510



PGC-2530



Test image
 (PGC-0510)

Installing jig for testing		
Fix the attachment to the force gauge	Grip samples	Hang it on the hook of attachment
		





Specifications			
Model	PGC-0505	PGC-0510	PGC-2530 (*1)
Features	The slim grip is ideal for a sample at a narrow space.	Lightweight standard model opens widely.	The high capacity model up to 2500N.
Capacity	500N	500N	2500N
Opening width	0.8~20mm	Max.15mm	
Max. sample thickness	6mm		10mm
Jaw width	5mm	10mm	30mm
Weight	Approx.170g	Approx.110g	Approx.750g
Dimensions	See [Dimensions]		
Mounting screw	- (*2)		M10
Hole for a hook	φ6		-

- * Some samples may not be suitable to grip with this product.
- * Weight of the attachment is also applied as a load on the force gauge. Please check the weight when selecting the capacity of a force gauge.
- * Ideal for gripping deformable samples like rubber, resin, etc. It is not suitable for hard sample like heat-treated steel.
- *1 PGC-2530 can NOT be attached to test stand to grip samples due to the influence of its own weight.
- *2 A standard attachment small hook (A-1/S-1/SR-1) is necessary to attach PGC to a force gauge.

Examples of Product Configuration PGC-0505	
Example 1 Code : 1P2014A	
Functional and advanced tensile test for capacity up to 500N Digital force gauge: ZTS-500N Motorized test stand: MX2-500N Optional attachment: PGC-0505 Optional attachment: GT-30 (Vice grip) Optional cable: CB-528 Optional Software: Force Recorder Standard	
Examples of Product Configuration PGC-0510	
Example 1 Code : 1P2015A	
Functional and advanced tensile test for capacity up to 500N Digital force gauge: ZTS-500N Motorized test stand: MX2-500N-L Optional attachment: PGC-0510 (2pcs) Optional adaptor: PGC-AD6 Optional cable: CB-528 Optional Software: Force Recorder Standard	
Examples of Product Configuration PGC-2530	
Example 1 Code : 1P2016A	
Functional and advanced tensile test for capacity up to 2500N Digital force gauge: ZTS-2500N Motorized test stand: MX2-2500N Optional attachment: PGC-2530 Optional attachment: GTW-2500N Optional cable: CB-528 Optional Software: Force Recorder Standard	

PGC-0510
Example 1 Image

- * Refer to the specification of each product for details.
- * Product configuration varies depending on the shape and characteristic of the sample, and measurement conditions. Please contact us or authorized distributor for further details.
- * The recommended capacity of force gauge varies depending on the expected loading forces.
- * Consider the stroke of test stand when testing extensible samples.

Mountable Force Gauge for PGC-0505 and PGC-0510		
DST/DSV series	ZTS/ZTA series	FB/PS/PSM series
Digital force gauge with excellent cost-performance capable to manage data with PC.	Digital force gauge with high precision, featuring high sampling rate and a variety of useful functions.	Mechanical force gauge for easy handling.
		
Mountable Force Gauge for PGC-2530		
High capacity ZTS/ZTA series	PSH series	
Digital force gauge with high precision, featuring high sampling rate and a variety of useful functions.	Mechanical force gauge for easy handling.	
		

Related Products		
Small grip SC-3/SC-8	Film grip FC-21/20/40/21U/41U/21UQ	Wedge grip KC series
Designed to grip small sample. Enables to clamp samples firmly due to gears on gripping parts.	Ideal for measuring of thin sample like film.	Wedge grip for gripping thin samples firmly with wedged surface.
		
Wire clamp CW-5000	Knurled cam grip GP-30	Optional adaptor PGC-AD6
Fix samples with single action. Wedge chuck grips samples firmly.	Knurled cam attachment for clamping wire or cable.	An adaptor to mount PGC-0505/PGC-0510 to test stand.
		

[Dimensions]

PGC-0505

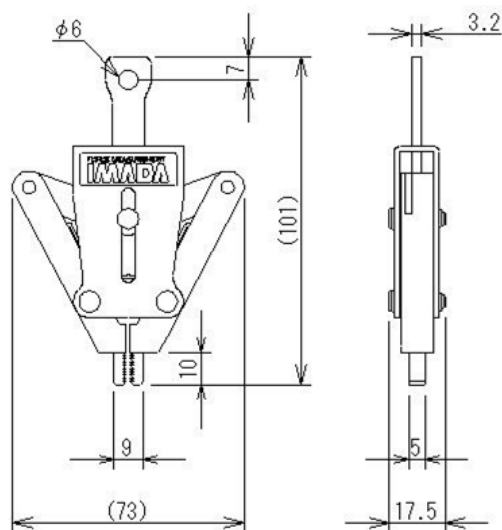

PGC-0510

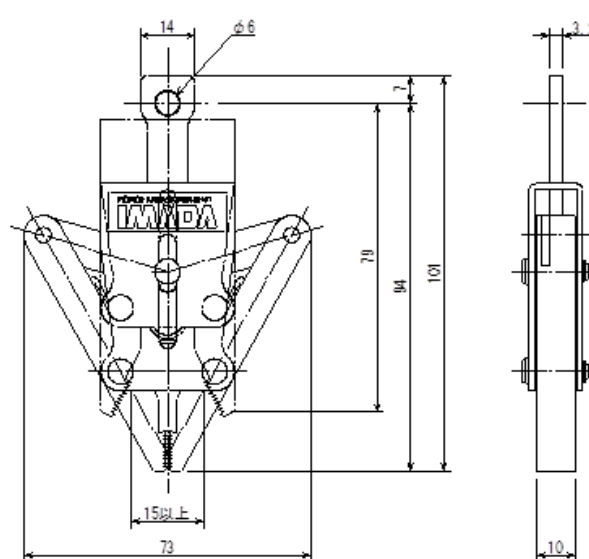

PGC-2530

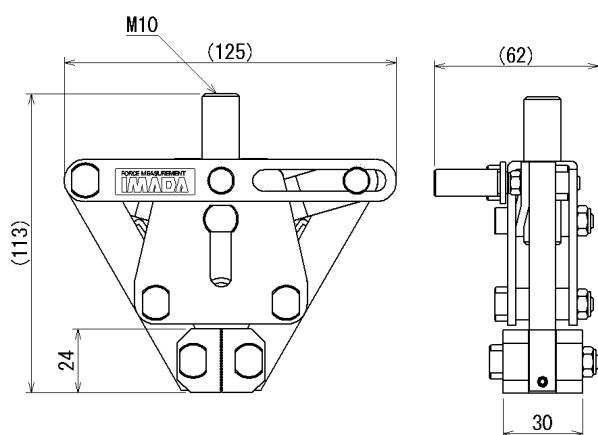

Unit: mm

[Cautions]

- Information in this document is subject to change without prior notice.
- This document is product descriptions and handling precautions, and do not guarantee various characteristics or safety.
- This product is designed for force measurement purpose only.
- Do not copy and use this content without authorization.
- A force gauge (sold separately) is required to use this product.
- Some samples may not be suitable to measure with this product.

IMADA CO., LTD

99 Jinnoshinden-cho aza Kanowari Toyohashi
Aichi Japan 441-8077
Tel: +81-(0)532-33-3288
Fax: +81-(0)532-33-3866
E-mail: info@forcegauge.net
Website: <https://www.forcegauge.net/en/>



Visit our website for more information on a wide range of product specifications, measurement applications and videos.