

Horizontal Manual Test Stand SH series

Allows set sample easily due to its horizontal design
Enables to apply force stably by operating handle

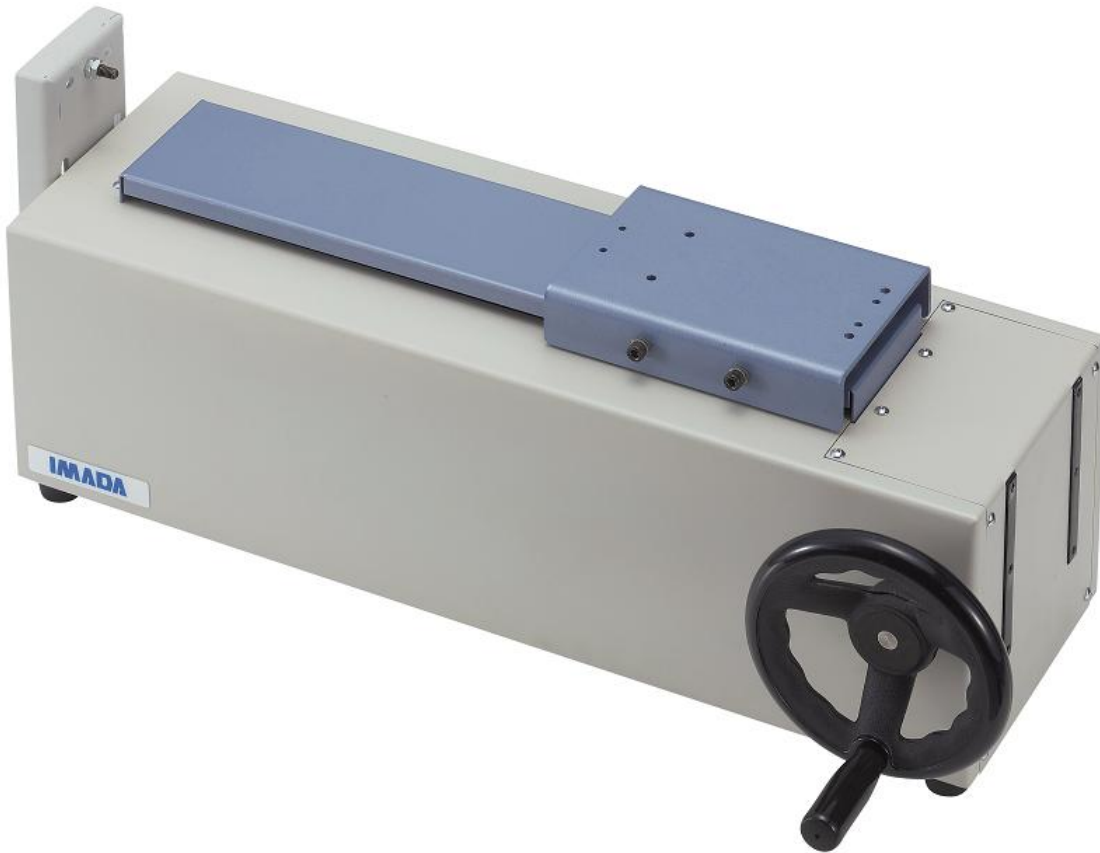

SH-1000N

Feature 1	Feature 2	Feature 3
Fine Movement	Rugged cover to prevent fragments from entering inside	Various testing applications
Allows fine adjustment of a force gauge's position and stable testing by the handle operation.	Designed for preventing fragments from entering inside when the samples fly apart during the measurement.	Suitable for measuring various forces such as tensile strength, compressive strength, and shear strength.

[Specifications]

Model	SH-1000N	SH-3000N
Capacity	1000N	3000N
Loading Method	Trapezoidal screw with 3mm lead	Ball screw with 4mm lead
Travel Rate	1.2mm/ 1 turn	0.6mm/ 1 turn
Max. Sample Length	Approx. 250mm *1	Approx. 355mm *1
Weight	Approx. 15kg	Approx. 22kg
Dimensions	See [Dimensions]	
Available Options	-S: Length scale	

*1 This value is the maximum distance between the attachment bracket and the tip of force gauge measuring shaft.

(SH-1000N: When up to 1000N model of ZTS/ZTA series, SH-3000N: When over 2500N model of ZTS/ZTA series is mounted.)



[Mountable Force Gauges]

	SH-1000N	SH-3000N
DST/DSV-2N to 1000N	✓	✓
ZTS/ZTA-2N to 1000N	✓	✓
ZTS/ZTA-2500N to 5000N	N/A	✓
DPU-2N to 500N	N/A	N/A
DPUH-1000N to 5000N	N/A	N/A
FB/FS/PS/PSS/PSM series	✓	✓
PSH series	N/A	✓

* Load cells not listed cannot be mounted on any of our test stands.

* Ensure to use within the capacity of force gauge and test stand regardless of the mountable models.

[Related Products]

Digital Force Gauge ZTS/ZTA series	Digital Force Gauge DST/DSV series	Mechanical Force Gauge FB series
Digital force gauge capable of measuring at a sampling rate of 2000 Hz.	Digital force gauge with excellent cost-performance capable of managing data with PC.	Mechanical force gauge for easy handling.
		

[Dimensions]

SH-1000N

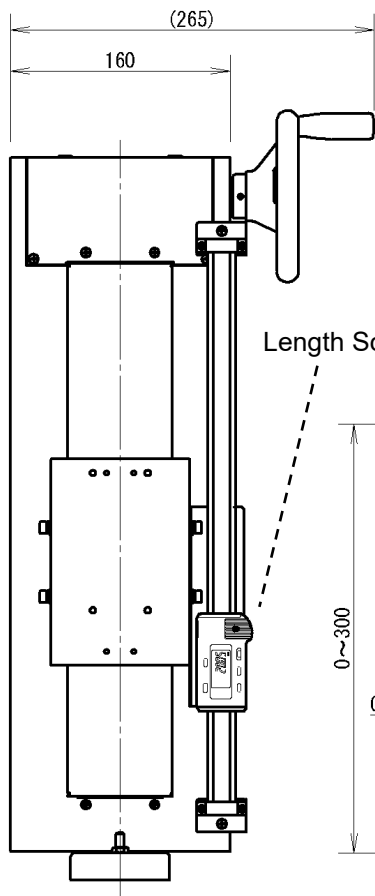
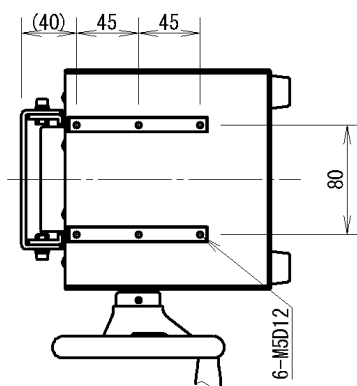
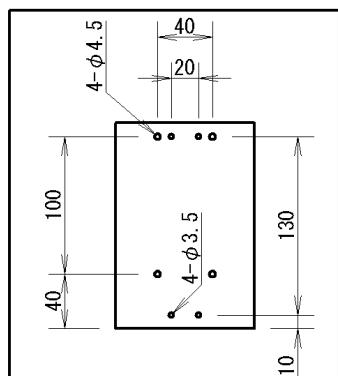

Length Scale

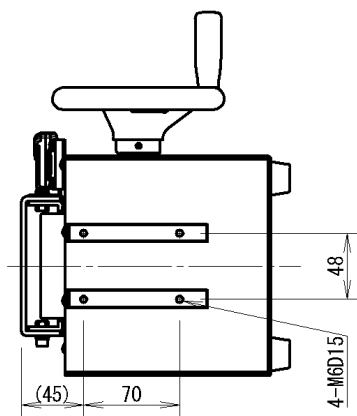
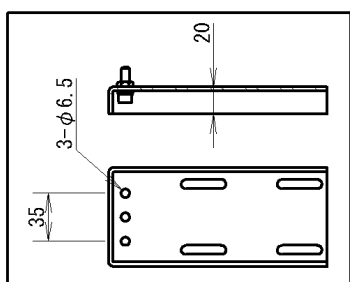
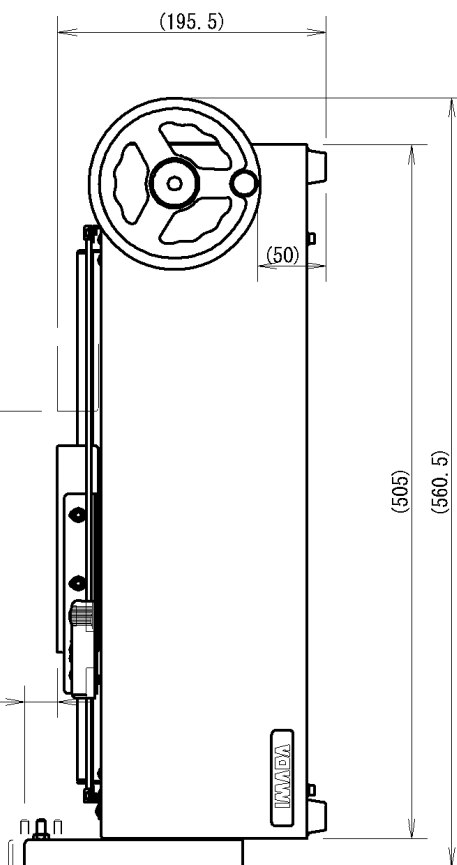

Unit: mm

SH-3000N

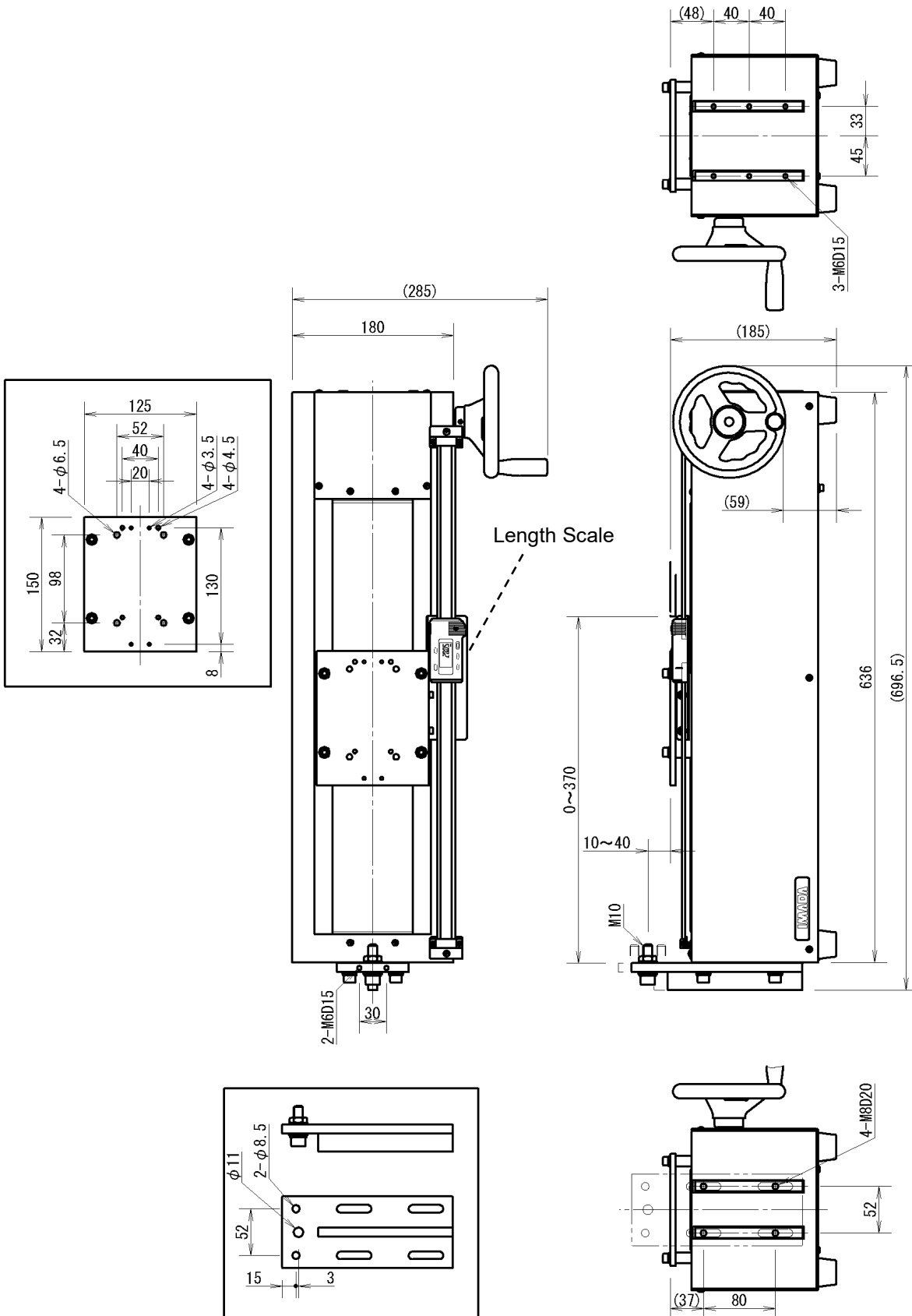

Unit: mm

[Cautions]

- Information in this document is subject to change without prior notice.
- This document is product descriptions and handling precautions, and do not guarantee various characteristics or safety.
- This product is designed for force measurement purpose only.
- Do not copy and use this content without authorization.
- A force gauge (sold separately) is required to use this product.
- Do not use this product in the environments including fierce temperature changes, high temperature, high humidity, near water, dusty place

IMADA CO., LTD

99 Jinnoshinden-cho aza Kanowari Toyohashi
Japan 441-8077
Tel: +81-(0)532-33-3288
Fax: +81-(0)532-33-3866
E-mail: info@forcegauge.net
Website: <https://www.forcegauge.net/en/>



Visit our website for more information on wide product specifications, measurement applications and videos.