

High Capacity Compression Jig SQ Series (Rectangle type)

Ideal for high capacity compression/breaking test up to 5000N.

Ensures accurate measurement due to free joint design. (SQ-5075/SQ-5150 only)

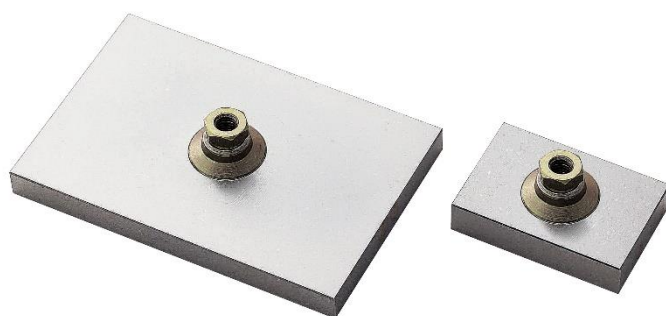

Suitable for compression test of tablet or plastic packaging.



SQ-5150 (left) SQ-5075 (right)



SQ-5030 Testing Image

Installing jig for testing		
Fix the jig to the force gauge	Set the sample	Compress to measure
		

Specifications			
Model	SQ-5030	SQ-5075	SQ-5150
Capacity	5000N		
Board attachment part	M5 Nut *1	φ32mm (Magnet)	
Dimensions	See [Dimension]		
Weight *2	Approx. 65g	Approx. 500g	Approx. 1560g
Mounting thread	M10		

*1 According to the position and the shape of the sample, unbalanced load might happen during the measurement. Since SQ-5030 does not have free joint design, using the universal joint is recommended for more precise measurement. (Separately sold)

*2 Weight of the attachment is also applied as a load on the force gauge. Consider it when selecting the capacity of a force gauge.



Examples of Product Configuration SQ-5150	
<p>Example 1 Code: 1S2003A</p> <p>For functional and versatile testing up to 5000N</p> <p>Digital Force Gauge: ZTS-5000N Motorized Test Stand: MX2-5000N Optional Attachment: SQ-5150 Optional Cable: CB-528 *1</p>	 <p>SQ-5150 Example 1 Image</p>

* Refer to specifications of each product for details.

* Product configuration varies depending on the shape and characteristic of the sample, and measurement conditions.

* The recommended capacity of force gauge varies depending on the expected force to be loaded.

*1 Durability test with predetermined force and time can be activated by using optional cable.

Mountable Force Gauge	
High Capacity ZTS/ZTA series	PSH series
Digital force gauge with high precision, featuring high sampling rate and a variety of useful functions.	Mechanical force gauge for easy handling.
	

* Refer to specifications of the individual product for details.

* Select suitable force gauge to correspond with the mounting screws of attachment.

Related Products		
High Capacity Compression Jig [Disc type] PC series	High Capacity Compression Jig [Spherical type] SP series	Durability Test Fixture PR-500N/2500N
Ideal for high capacity compression/breaking testing up to 5000N. They can contact a test samples closely due to a free joint design.	For high capacity compression and breaking test up to 5000N.	Ideal for durability tests for retort pouch, heat sealed package, up to 2500N.
		
Conversion Adapter CA series	Universal Joint UJ6-1000N/UJ10-5000N	
For mounting a M10 screw attachment to a M6 screw thread of a force gauge.	An optional attachment to prevent unbalanced load.	
		

* Refer to specifications of the individual product for details.

[Custom made solutions]

We offer custom made options including change of diameter, materials (stainless only), or adding air vent and slit machining. Please contact us for details.

[Dimension]

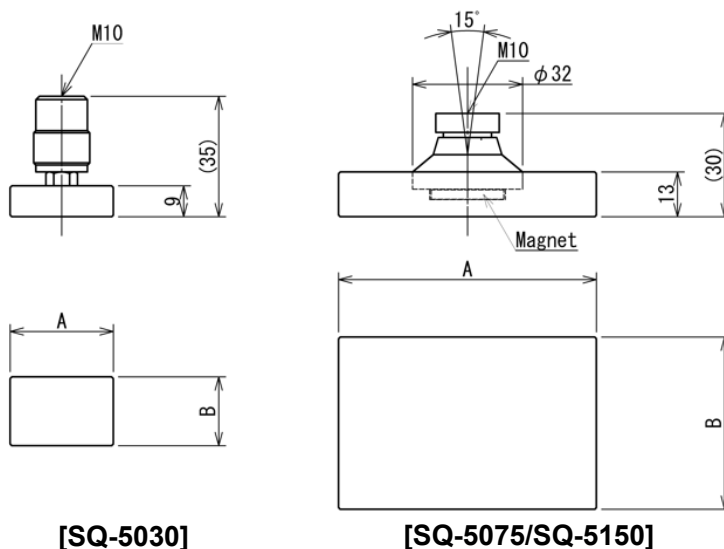

Model	A	B
SQ-5030	30	20
SQ-5075	75	50
SQ-5150	150	100

Unit: mm

[Cautions]

- Information in this document is subject to change without prior notice.
- This document is product descriptions and handling precautions, and do not guarantee various characteristics or safety.
- This product is designed for force measurement purpose only.
- Do not copy and use this content without authorization.
- A force gauge (sold separately) is required to use this product.
- Some samples may not be suitable to measure with this product.

IMADA CO., LTD.

99, Jinnoshinden-Cho, Aza, Kanowari, Toyohashi,
Aichi 441-8077, JAPAN
Tel: +81-(0)532-33-3288
Fax: +81-(0)532-33-3866
E-mail: info@forcegauge.net
Website: <https://www.forcegauge.net/en/>



Visit our website for more information on a wide range of product specifications, measurement applications and videos.