

Film Puncture Test Fixture

TKS-20N / TKS-250N

- Designed for puncture strength testing of thin samples including film, PET bottles and aluminum
- Performs testing according to the corresponding part of JIS Z1707:2019



Simple affordable type for low-force:
TKS-20N



Testing Image



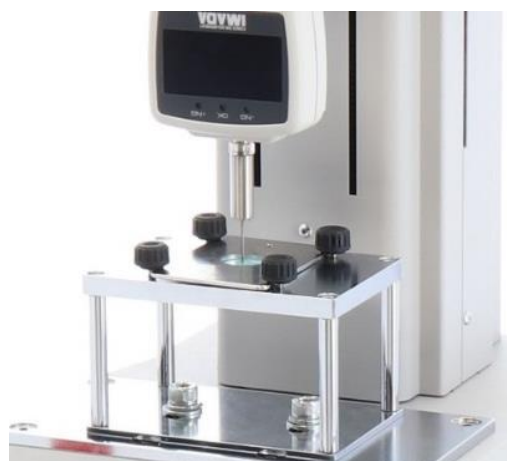

Standard type:
TKS-250N



Testing Image

Standard	JIS Z1707:2019 [General rules of plastic films for food packaging] (corresponding part only)
-----------------	---

Measuring Procedures (TKS-250N)		
Attach the pin to the measuring shaft of force gauge.	Ensure the pin comes in the center of the hole in the table.	Loosen the fixing plate knobs, set the sample and tighten the knobs.
		

Specifications			
Model	TKS-20N		TKS-250N
Capacity	20N		250N
Table	Diameter of Hole *1	10mm	20mm
	Weight	Approx. 500g	Approx. 1050g
	Sample Size	20x20 to 60x60 mm	40x40 to 55x55 mm
Pin	Diameter	1mm	
	Tip Shape	SR0.5	
	Material	Stainless Steel	Steel
	Weight	Approx. 0.2g	Approx. 16g
	Included Quantity	3 pcs	1 pc
Pin Vice	Available Diameter	Up to 3.2mm	-
	Weight	Approx. 22g	-
Mounting screw (Pin/Pin Vice)	M6		
Dimensions	See [Dimensions]		



*1 Diameter of hole can be changed to meet your requirements. Contact us for details.

* Weight of the attachment is also applied as a load on the force gauge. Consider it when selecting the capacity of a force gauge.

* Pins may break or bend when offset load is applied.



* Some samples may not be suitable to hold and test with this product.

[Pins for replacement] Pin parts are available for replacement.

Model	Included Parts	Images		
TP-10	Set of pins for TKS-20N (pin part-3pcs) and pin vice *1			
STP-001	Pins for TKS-20N (pin part-3pcs) only *1			
TP-20	Pin for TKS-250N			
		TP-10	STP-001	TP-20



*1 Pins come in 3 pcs. Single piece of purchase is not available.

[Table] Only the table part is also available for purchase.

Model	Included Parts	Images	
TTB-10	Table for TKS-20N Hole diameter: 10 mm	 TTB-10	 TTB-20
TTB-20	Table for TKS-250N Hole diameter: 20 mm *1		

* Use with pins of your choice for testing.



*1 Diameter of hole can be changed to meet your requirements. Contact us for details.



Examples of Product Configuration TKS-20N	
<p>Example 1 Code: 1T2001A Simple testing up to 20N</p> <p>Digital Force Gauge: DST-20N Motorized Test Stand: MX-500N Optional Attachment: TKS-20N</p>	 TKS-20N Example 2 Image
<p>Example 2 Code: 1T2001B Testing up to 20N according to a part of JIS Z 1707:2019 General rules of plastic films for food packaging</p> <p>Digital Force Gauge: ZTS-20N Motorized Test Stand: MX2-500N Optional Attachment: TKS-20N Optional Cable: CB-528</p>	
Examples of Product Configuration TKS-250N	
<p>Example 1 Code: 1T2002A Simple testing up to 250N</p> <p>Digital Force Gauge: DST-20N Motorized Test Stand: MX-500N Optional Attachment: TKS-250N</p>	 TKS-250N Example 2 Image
<p>Example 2 Code: 1T2002B Testing up to 250N according to a part of JIS Z 1707:2019 General rules of plastic films for food packaging</p> <p>Digital Force Gauge: ZTS-500N Motorized Test Stand: MX2-500N Optional Attachment: TKS-250N Optional Cable: CB-528 Optional Software: Force Recorder Standard</p>	



* Refer to the specification of each product for details.

* Product configuration varies depending on the shape and characteristic of the sample, and measurement conditions.

* The recommended capacity of force gauge varies depending on the expected force to be loaded.

Mountable Force Gauges for TKS-20N/TKS-250N		
DST/DSV series	ZTS/ZTA series	FB/PS/PSM series
Digital force gauge with excellent cost performance capable to manage data with PC.	Digital force gauge with high precision, featuring high sampling rate and a variety of useful functions.	Mechanical force gauge for easy handling.
		

Related Products		
Film Grip FC-21/20/40/21U/41U/21UQ	Cam Grip GR-30/GR-2000	Roller Grip GC-60/GC-100
Designed for tensile and peel testing to grip thin samples such as film with capacity of up to 500N.	Designed for efficient tensile testing of thin samples in rectangular shape, such as paper and sheet, with capacity of 2000N.	Ideal for extensible samples such as film and rubber without slipping for testing up to 500N.
		

Related Tests	
Breaking tensile strength test of film to check whether it meets the requirement of IEC 60286-3(2013) and JIS C0806-3(2014).	Tensile strength test of heat sealed parts according to a part of JIS Z 1707:2019 7.5. A part of JIS Z0238:1998 can be also conformed.
	
Product Configuration (*) Code: 1G2005A Digital force gauge: ZTS-200N Motorized test stand: MX2-500N-L Optional attachment: GC-60 (2 pieces) Optional cable: CB-528	Product Configuration (*) Code: 1F2003A Digital force gauge: ZTS-200N Motorized test stand: MX2-500N Optional attachment: FC-21U (2 pieces) Optional cable: CB-528

* Refer to the specification of each product for details.

* Product configuration varies depending on the shape and characteristic of the sample, and measurement conditions.

* The recommended capacity of force gauge varies depending on the expected force to be loaded.

[Dimensions]

TKS-20N

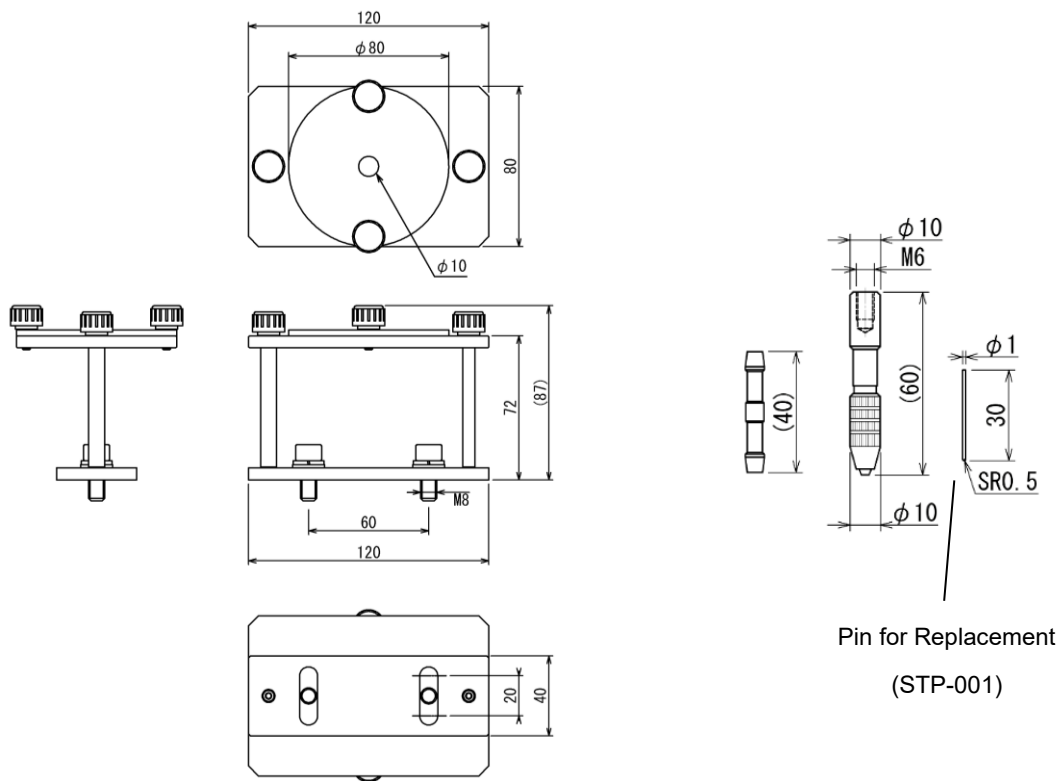

TKS-250N

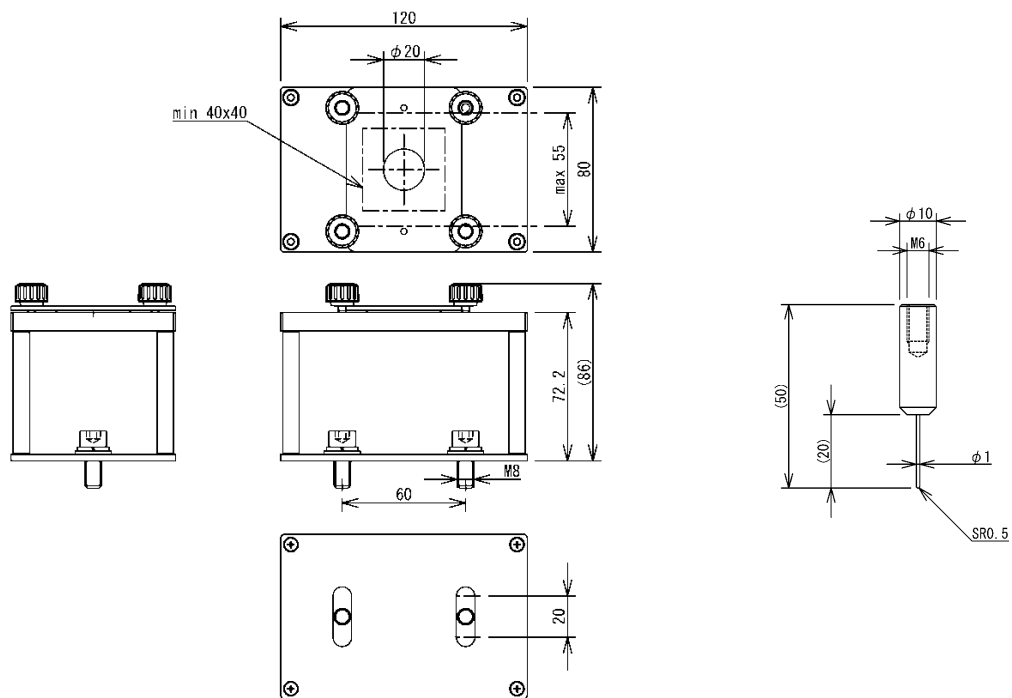

Unit: mm

[Cautions]

- Information in this document is subject to change without prior notice.
- This document is product descriptions and handling precautions, and do not guarantee various characteristics or safety.
- This product is designed for force measurement purpose only.
- Do not copy and use this content without authorization.
- A force gauge (sold separately) is required to use this product.
- Some samples may not be suitable to measure with this product.

IMADA CO., LTD

99 Jinnoshinden-cho aza Kanowari Toyohashi
Japan 441-8077
Tel: +81-(0)532-33-3288
Fax: +81-(0)532-33-3866
E-mail: info@forcegauge.net
Website: <https://www.forcegauge.net/en/>



Visit our website for more information on a wide range of product specifications, measurement applications and videos.