

Urethane Hemisphere Head Compression Jig UR series

Soft texture like finger is ideal for final inspection before shipment, preventing damage to the measurement sample

Two types of hardness are available for your measurement needs



UR series

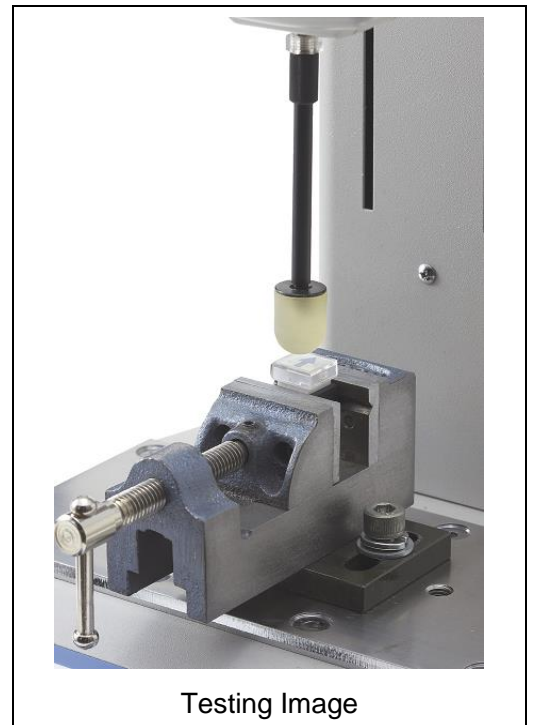

Testing Image

Installing jig for testing		
Fix the jig to the Force gauge	Set the sample	Start to measure

Specifications		
Model	UR-8S	UR-8M
Max. Capacity(N)	50	50
Dimension	See [Dimension]	
Hardness	Shore A50 Hardness like eraser	Shore A70 Hardness like Rubber ball for baseball
Weight(g) *1	Approx. 5	Approx. 5
Mounting Screw	M6	

* Unavailable for the capacitance touch panel.



*1 Weight of the attachment is also applied as a load on the force gauge. Consider it when selecting the capacity of a force gauge.

Example of Product Configuration	
<p>Example1 Code:1U2001A -Simple manual compression test up to 50N</p> <p>Digital force gauge: DST-50N Manual test stand: KV-50N Option attachment: UR-8S</p>	 <p>Example1 image</p>
<p>Example2 Code:1U2001B - Force-displacement measurement up to 50N for compression</p> <p>Force-displacement measurement system: FSA-0.5K2-50N Option attachment: UR-8S</p>	



* Refer to specifications of each product for details.

* Product configuration varies depending on the shape and characteristic of the sample, and measurement conditions.

* The recommended capacity of force gauge varies depending on the expected force to be loaded.

Related Products		
<p>Compression Test fixture for small spot PG-2/3/4/5</p>	<p>Compression Circle Plate A-40/60,S-40/60</p>	<p>High capacity Spherical fixture SP series</p>
<p>Ideal for compression and penetration test of small samples</p>	<p>Suitable for crashing test. Type A is made of aluminum and Type S is made of steel</p>	<p>For high capacity compression and breaking test up to 5000N</p>
		

* Refer to specifications of the individual product for details.

Mountable Force gauge		
Digital DST/DSV series	Digital ZTS/ZTA series	Mechanical FB/PS/PSM series
Digital force gauge with excellent cost-performance capable to manage data with PC	Digital force gauge with high precision, featuring high sampling rate and a variety of useful functions.	Mechanical force gauge for easy handling
		

* Refer to specifications of the individual product for details.

* Select suitable force gauge to correspond with the mounting screws of attachment.

[Custom made solutions]

Custom-made options are available for your measurement needs. (e.g. changing the material, size, etc.) Please contact authorized local distributor or us for details.

[Dimension]

UR-8S/UR-8M

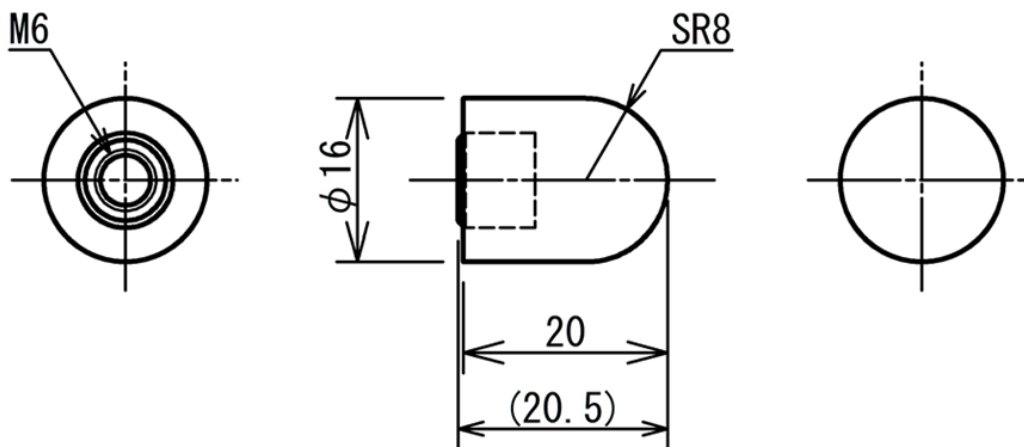

Unit: mm

[Cautions]

- Information in this document is subject to change without prior notice.
- This document is product descriptions and handling precautions, and do not guarantee various characteristics or safety.
- This product is designed for force measurement purpose only.
- Do not copy and use this content without authorization.
- A force gauge (sold separately) is required to use this product.
- Some samples may not be suitable to measure with this product.

IMADA CO., LTD.

99, Jinnoshinden-Cho, Aza, Kanowari, Toyohashi,
Aichi 441-8077, JAPAN
Tel: +81-(0)532-33-3288
Fax: +81-(0)532-33-3866
E-mail: info@forcegauge.net
Website: <http://www.forcegauge.net/en/>



Visit our website for more information on a wide range of product specifications, measurement applications and videos.